



# LAMPIRAN

## Lampiran 1

Tabel 2.2 Sifat mekanik AISI 304 <sup>[4]</sup>

Poison	Tensile	Yield	Elong	Hard	Mod	Density
0,27- 0,30	515	205	40	88	193	8

*Keterangan :*

Poison : Rasio Poison  
Tensile : Tensile strength (MPa)  
Yield : Yield Strength (MPa)  
Elong : elongation %  
Hard : Kekerasan (HVN)  
Mod : Modulus elastisitas (GPa)  
Density : berat jenis (Kg/m<sup>3</sup>)

Tabel sifat mekanik, (Gadang priyotomo, 2013)

## Lampiran 2



Bawang putih sebelum dikupas



Bawang putih setelah dikupas

### Lampiran 3



Hasil pengujian 10 menit



Hasil pengujian 15 menit



#### Lampiran 4



Hasil pengujian 20 menit



Hasil pengujian 25 menit

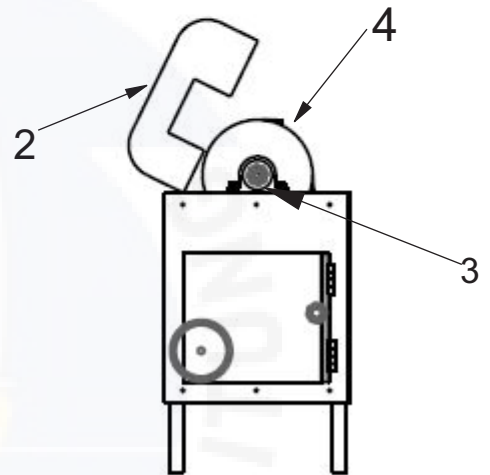
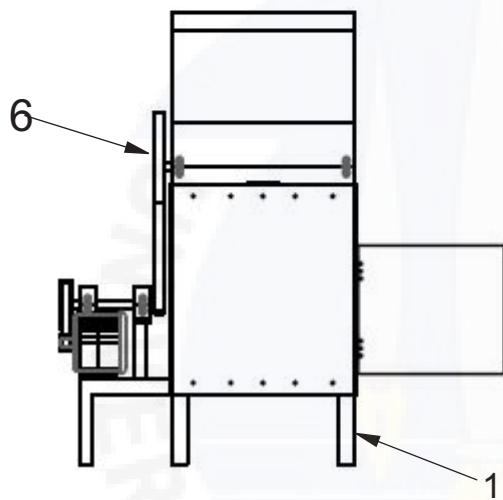
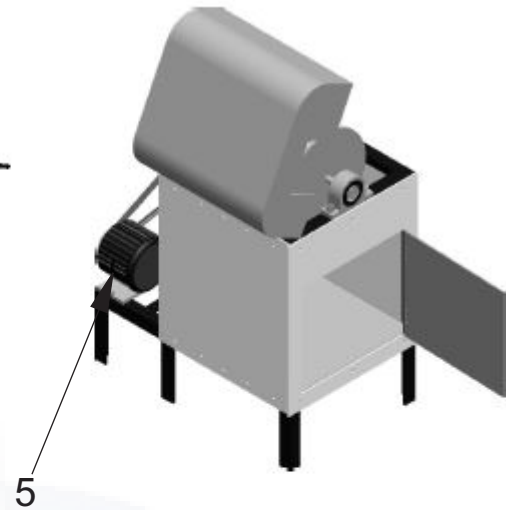
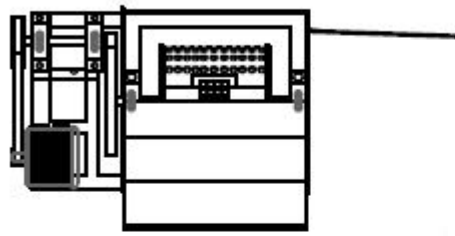

	4	Pulley	6	Alumunium				
	1	Mesin	5					
	1	Wadah Silinder	4	Alumunium				
	1	Poros Pengupas	3	Stainless 304				
	1	Cover	2	Alumunium				
	1	Rangka	1	Baja				
Jumlah		Nama Bagian	No. Bag	Bahan	Ukuran	Keterangan		
		<i>MESIN PENGUPAS KULIT BAWANG PUTIH</i>			SKALA	DIGAMBAR	21-07-2017	Amrul Haqqi
					1:20	DIPERIKSA		
						DILIHAT		
						DISETUJUI		
				<i>UNIVERSITAS BANGKA BELITUNG</i>				

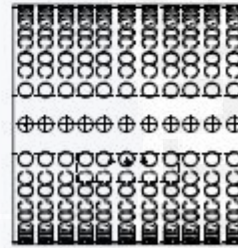
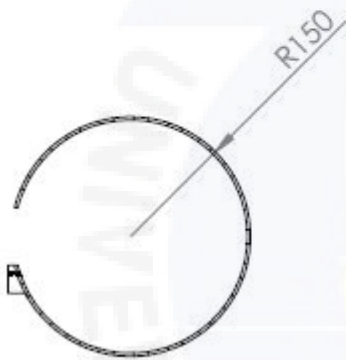
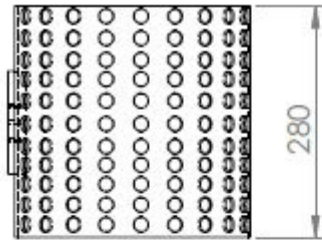

*WADAH SILINDER*

*UNIVERSITAS BANGKA BELITUNG*

SKALA	DIGAMBAR	25-07-2017	Amrul haqqi
1:20	DIPERIKSA		
	DILIHAT		
	DISETUJUI		

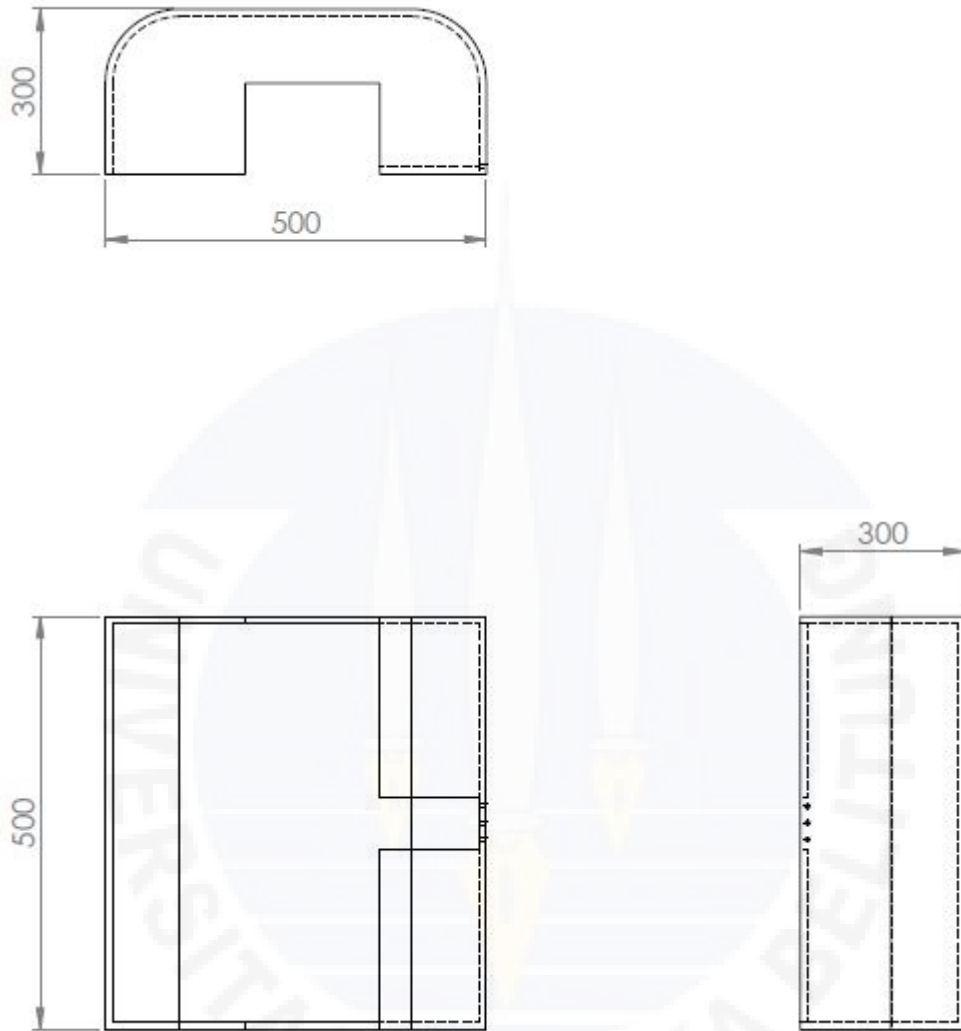

<i>COVER</i>	SKALA	DIGAMBAR	25-07-2017	Amrul haqqi
	<i>1:20</i>	DIPERIKSA		
		DILIHAT		
		DISETUJUI		
<i>UNIVERSITAS BANGKA BELITUNG</i>				



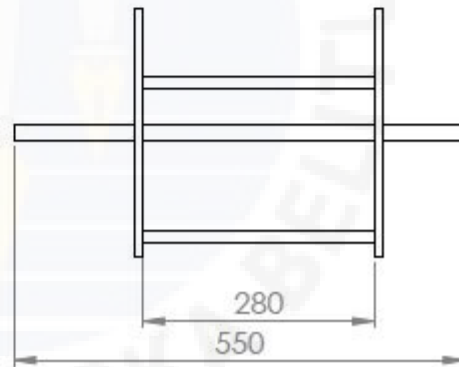
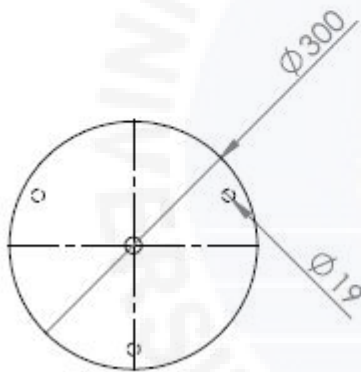
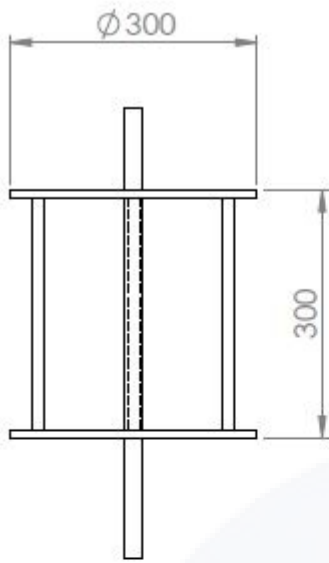

## POROS PENGUPAS

UNIVERSITAS BANGKA BELITUNG

SKALA	DIGAMBAR	25-07-2017	Amrul haqqi
1:20	DIPERIKSA		
	DILIHAT		
	DISETUJUI		

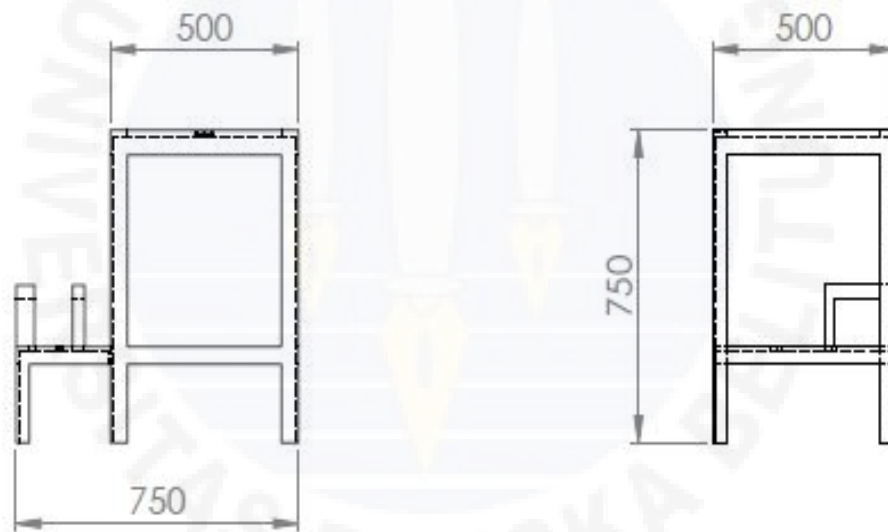
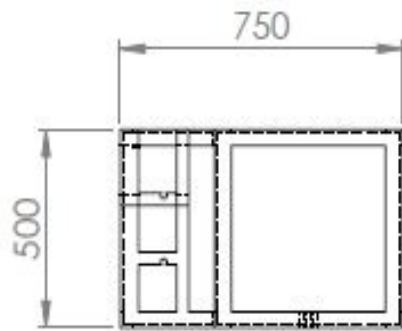

*RANGKA*

SKALA	DIGAMBAR	25-07-2017	Amrul haqqi
1:20	DIPERIKSA		
	DILIHAT		
	DISETUJUI		

*UNIVERSITAS BANGKA BELITUNG*