

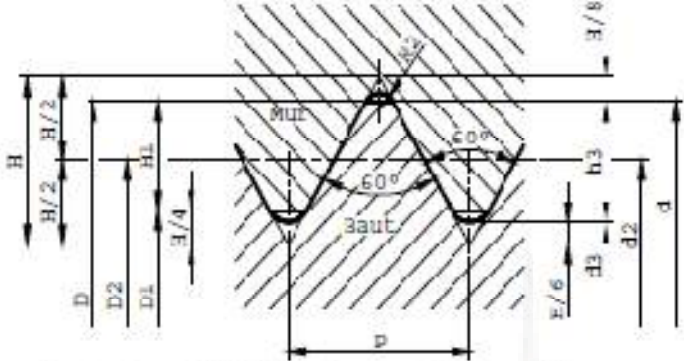





		Tabel Ulir ISO Metrik Normal				
ISO 261/63/262/R724						
				$D_2, d_2 = \text{Dia. tengah}$ $D_2 = d_2 = d - 0,649 P$ $D_1 = d - 1,082 P$ $d_1 = d - 1,226 P$ $H = 0,866 P$ $H_1 = 0,541 P$ $h_2 = 0,613 P$ $R_1 = 0,144 P$ $R_2 = 0,072 P$		
Perunjukkan can ulir metrik ISU, diameter nominal $d = 5 \text{ mm}$: M 5.						
Diameter nominal $d = D$	Gang P	Diameter Tengah $d_2 = D_2$	Baut		Mur	
			Diameter terkecil d_3	Luas tegangan tarik $A_s (mm^2)$	Diameter terkecil D_1	Diameter mata hr
M 1	0,25	0,838	0,69	0,46	0,73	0,75
M 1,2	0,25	1,038	0,89	0,73	0,93	0,95
M 1,6	0,35	1,373	1,71	1,27	1,22	1,26
M 2	0,4	1,740	1,61	2,07	1,67	1,6
M 2,5	0,45	2,208	1,95	3,39	2,01	2
M 3	0,5	2,675	2,39	5,03	2,46	2,5
M 4	0,7	3,545	3,14	8,78	3,24	3,3
M 5	0,8	4,480	4,02	14,2	4,13	4,2
M 6	1	5,350	4,77	20,1	4,91	5
M 8	1,25	7,188	6,17	38,6	6,65	6,8
M 10	1,5	9,026	8,16	58,0	8,37	8,5
M 12	1,75	10,863	9,85	84,3	10,10	10,2
(M 14)	2	12,700	11,55	115	11,83	12
M 16	2	14,701	13,55	157	13,83	14
(M 18)	2,5	16,376	14,93	192	15,29	15,5
M 20	2,6	18,376	16,03	246	17,20	17,6
(M 22)	2,5	20,376	18,93	303	19,29	19,5
M 24	3	22,051	20,32	353	20,75	21
(M 27)	3	25,051	23,32	459	23,75	24
M 30	3,5	27,727	25,71	501	26,21	26,5
(M 33)	3,5	30,726	28,71	603	29,21	29,5
M 36	4	33,402	31,09	817	31,87	32
(M 39)	4	36,401	34,09	975	34,87	35
M 42	4,5	39,077	36,48	1120	37,13	37,5
(M 45)	4,5	42,077	39,48	1306	40,13	40,5
M 48	5	44,752	41,87	1470	42,59	43
(M 52)	5	48,752	45,87	1758	46,59	47
M 56	5,5	52,427	49,25	2030	50,04	50,5
(M 60)	5,5	56,427	53,25	2362	54,04	54,5
M 64	6	60,102	56,64	2676	57,50	58
(M 68)	6	64,102	60,64	3055	61,50	62

Lampiran 2. Tabel Ulir (*Screw*)

	Tabel Beberapa Material	
Modulus elastisitas E dan koefisien kontraksi melintang μ .		
Material	E in N/mm ²	μ
Aluminium	70500	0,34
Paduan Aluminium	61000 bis 76500	≈ 0,33
Bronze	108000 bis 124000	0,35
Besi	≈ 206000	0,28
Emas	77500	0,42
Besi Tuang Kelabu	78500 bis 12800	≈ 0,25
Tembaga	123000	0,35
Paduan Tembaga	113000 bis 123000	≈ 0,34
Magnesium	28500	
Paduan Magnesium	39200 bis 44400	≈ 0,3
Kuningan	78500 bis 118000	0,35
Perak	80000	0,38
Baja	196000 bis 206000	0,3
Besi Tuang Duktill	≈ 167000	≈ 0,25
Titan	108000	0,27
Paduan Titan	103000 bis 123000	0,32 bis 0,38
Seng (Zn)	128000	0,2 bis 0,3
Timah Putih (Su)	55400	0,33

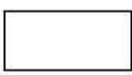
Lampiran 1. Lambang-lambang Dari Diagram Aliran

Lambang	Nama	Keterangan
	Terminal	Untuk menyatakan mulai (start), berakhir (end) atau berhenti (stop)
	Input	Data dan persyaratan yang diberikan disusun disini
	Pekerjaan orang	Di sini diperlukan pertimbangan-pertimbangan seperti pemilihan persyaratan kerja, persyaratan pengerjaan, bahan dan perlakuan panas, penggunaan faktor keamanan dan factor-faktor lain, harga-harga empiris, dll.
	Pengolahan	Pengolahan dilakukan secara mekanis dengan menggunakan persamaan, tabel dan gambar.
	Keputusan	Harga yang dihitung dibandingkan dengan harga Patoka, dll. Untuk mengambil keputusan
	Dokumen	Hasil perhitungan yang utama dikeluarkan pada alat ini
	Penghubung	Untuk menyatakan pengeluaran dari tempat keputusan ke tempat sebelumnya atau berikutnya, atau suatu pemasukan ke dalam aliran yang berlanjut.
	Garis aliran	Untuk menghubungkan langkah-langkah yang berurutan

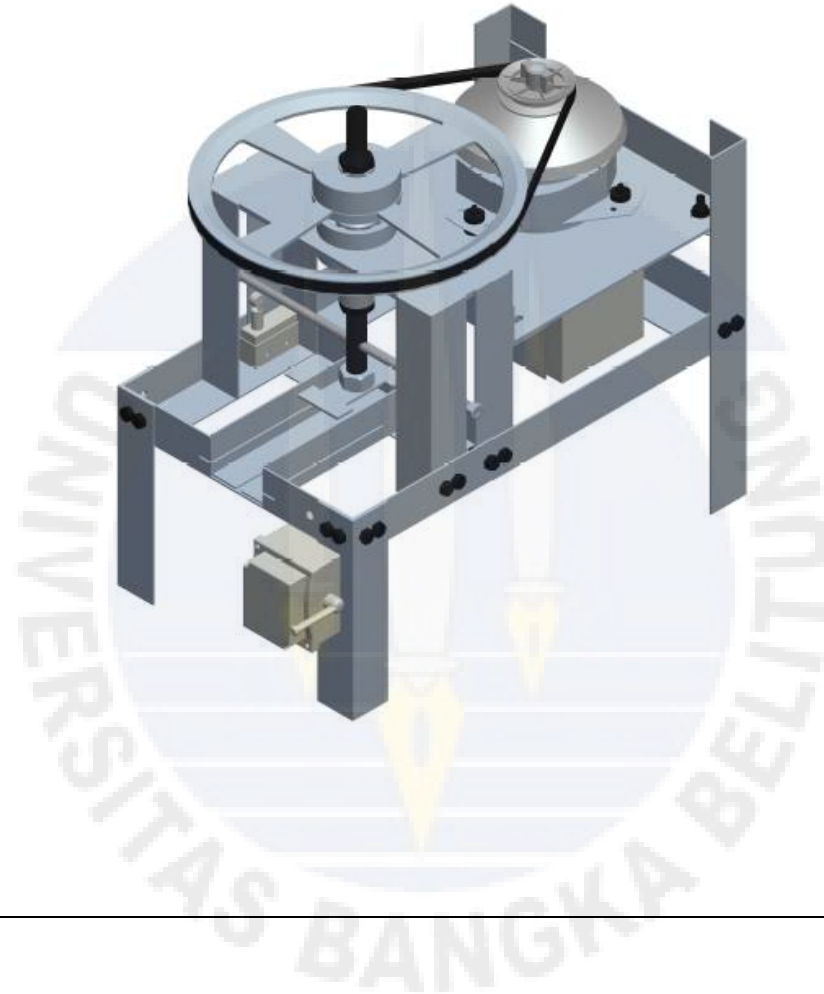

MESIN CETAK TERASI KAPASITAS 250 GRAM

Skala 1:10	Dilihat		
	Digambar		Rhendy
	Diperiksa		
	Disetujui		



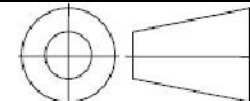

UNIVERSITAS BANGKA BELITUNG



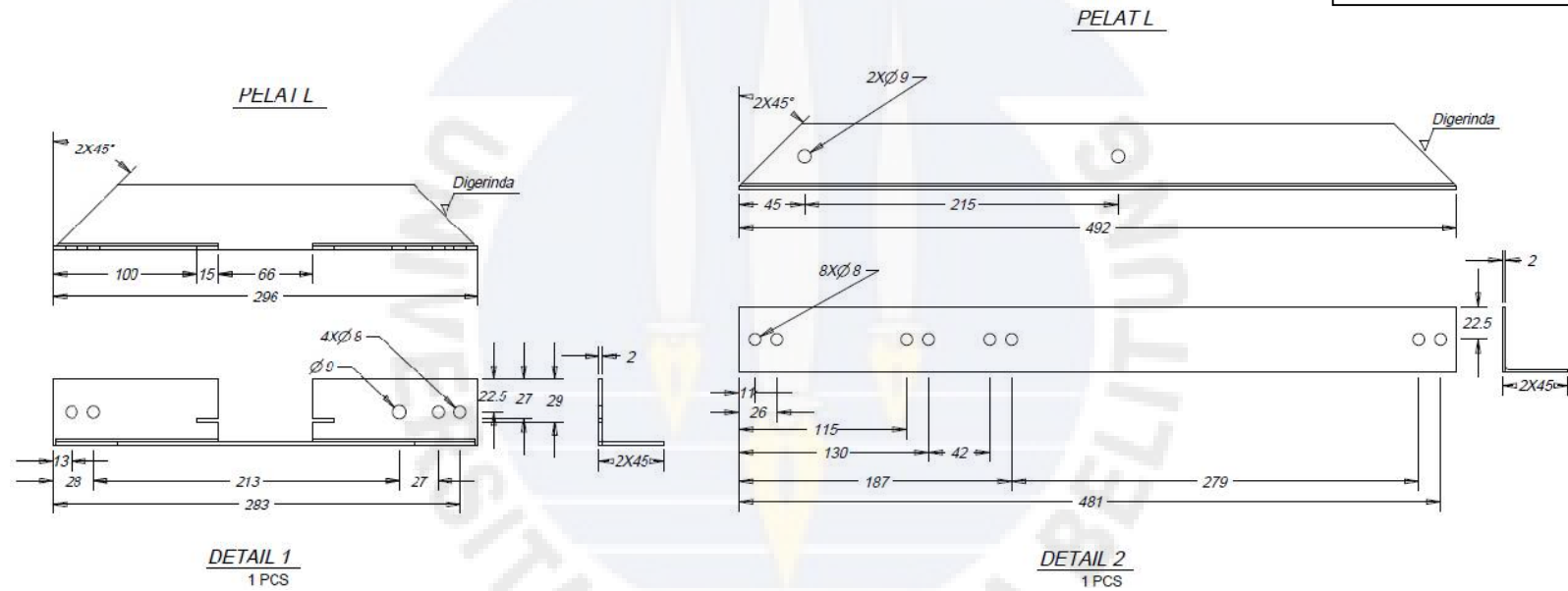
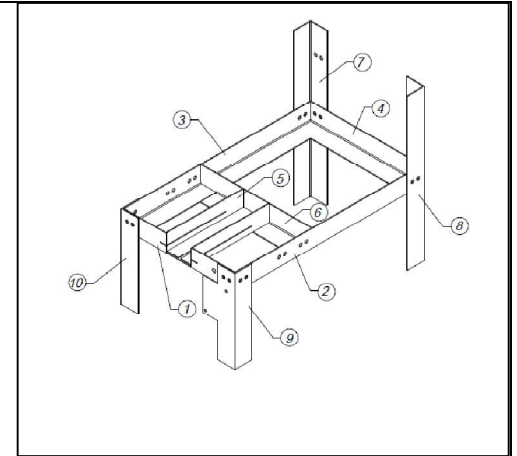

1

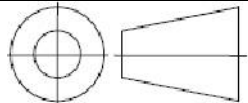

<p>RANGKA DUDUKAN MESIN CETAK TERASI KAPASITAS 250 GRAM</p>	Dilihat		
	Digambar		Rhendy
	Diperiksa		
	Disetujui		
 <p>UNIVERSITAS BANGKA BELITUNG</p>	<p>Skala 1:5</p>		



1

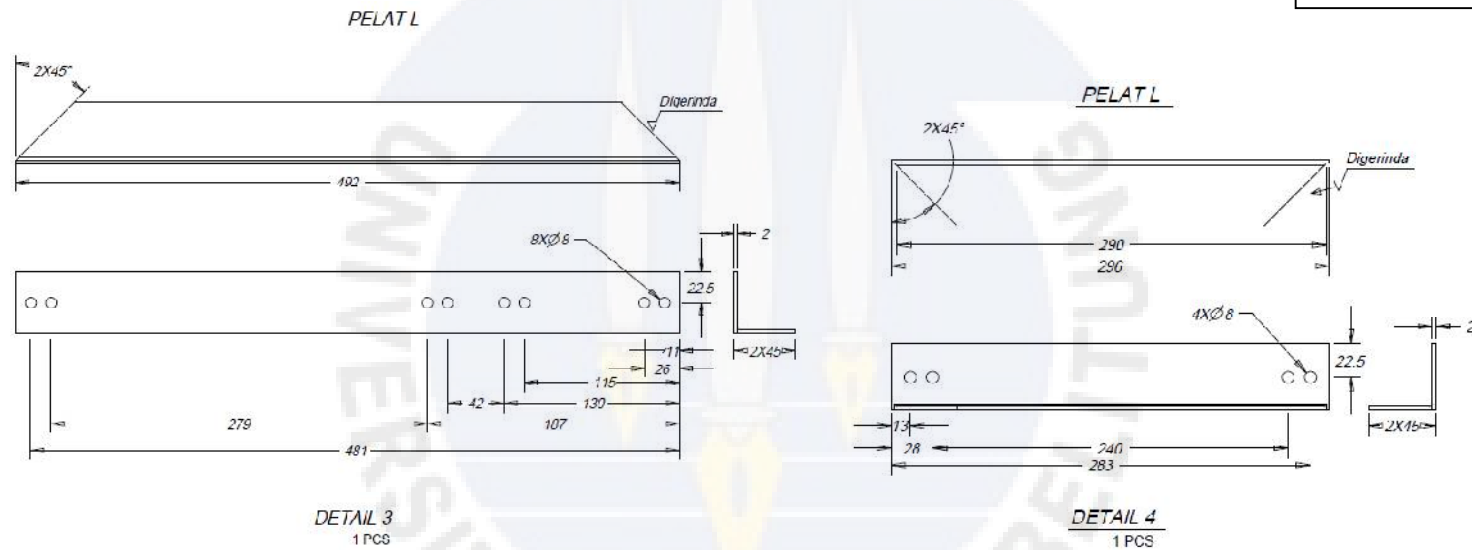
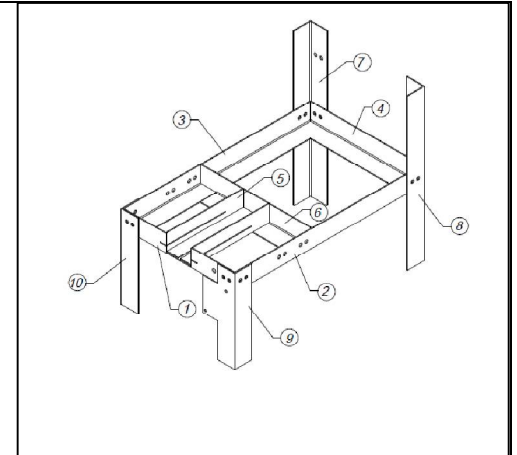

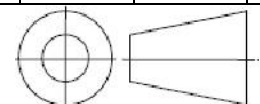
<p>RANGKA DUDUKAN MESIN CETAK TERASI KAPASITAS 250 GRAM</p>	<p>Dilihat</p>		
	<p>Digambar</p>		<p>Rhendy</p>
	<p>Diperiksa</p>		
	<p>Disetujui</p>		
<p>Skala 1:5</p>			
 <p>UNIVERSITAS BANGKA BELITUNG</p>			



1

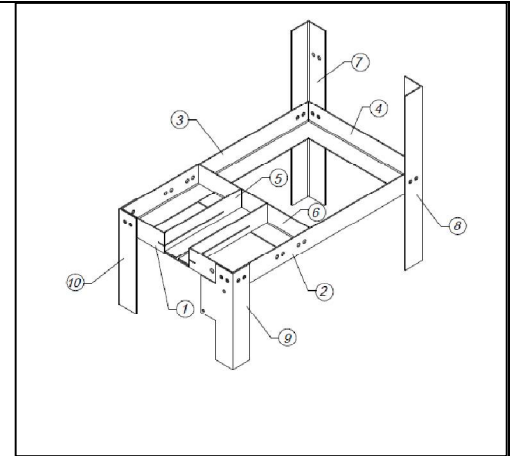
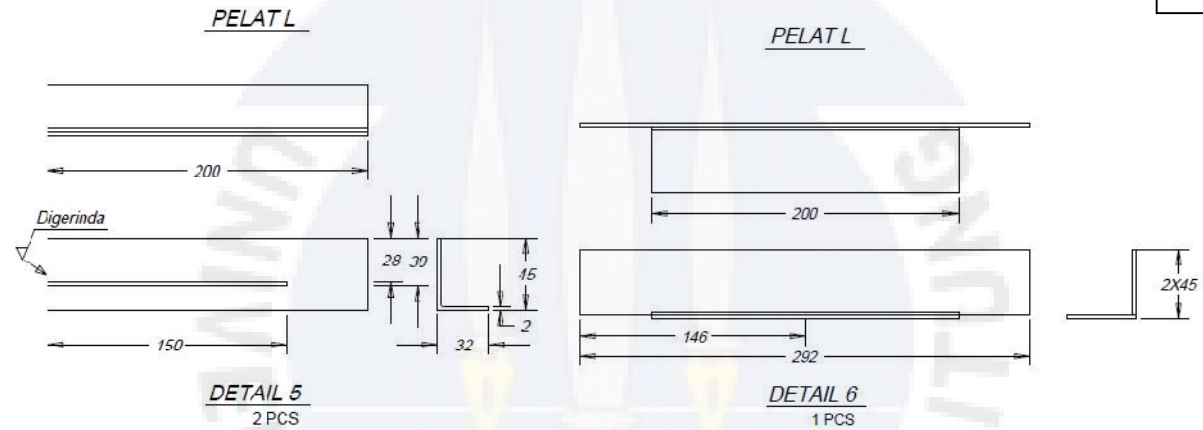

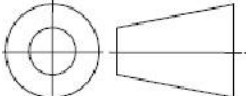
<p>RANGKA DUDUKAN MESIN CETAK TERASI KAPASITAS 250 GRAM</p>	Dilihat		
	Digambar		Rhendy
	Diperiksa		
	Disetujui		
 <p>UNIVERSITAS BANGKA BELITUNG</p>	Skala 1:5		



1

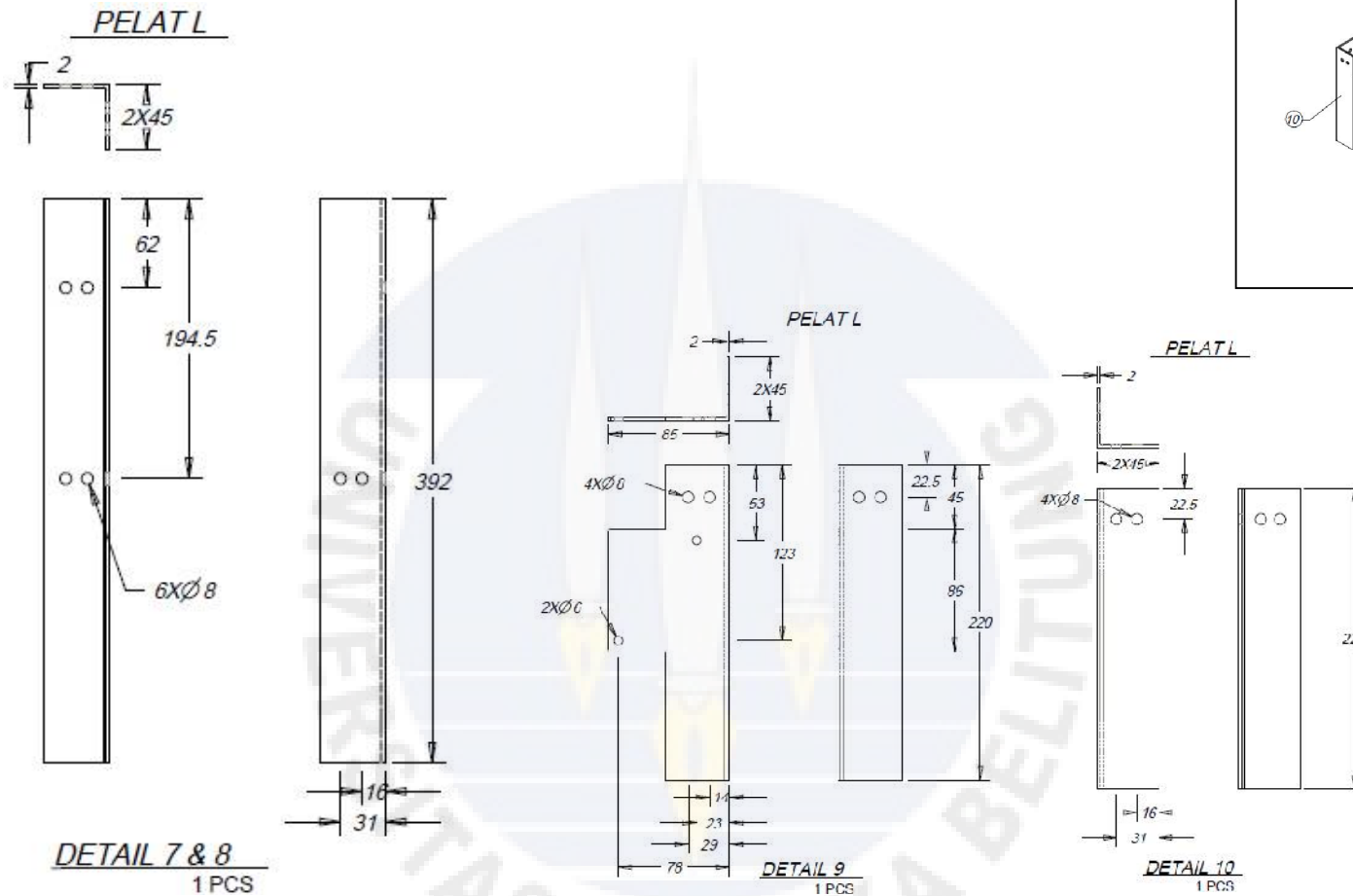

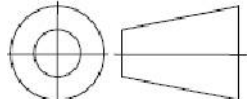
<p>RANGKA DUDUKAN MESIN CETAK TERASI KAPASITAS 250 GRAM</p>	<p>Skala 1:5</p>	Dilihat	
		Digambar	Rhendy
		Diperiksa	
		Disetujui	
 <p>UNIVERSITAS BANGKA BELITUNG</p>			



2

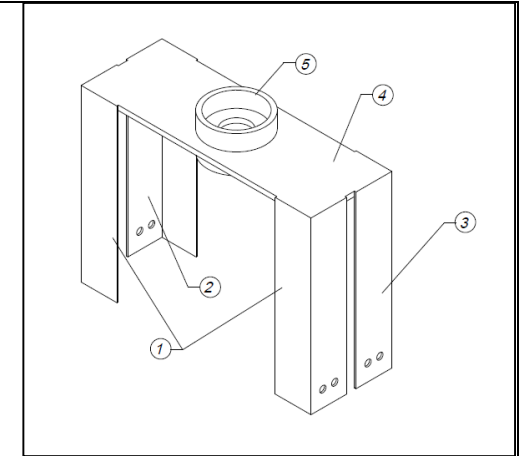
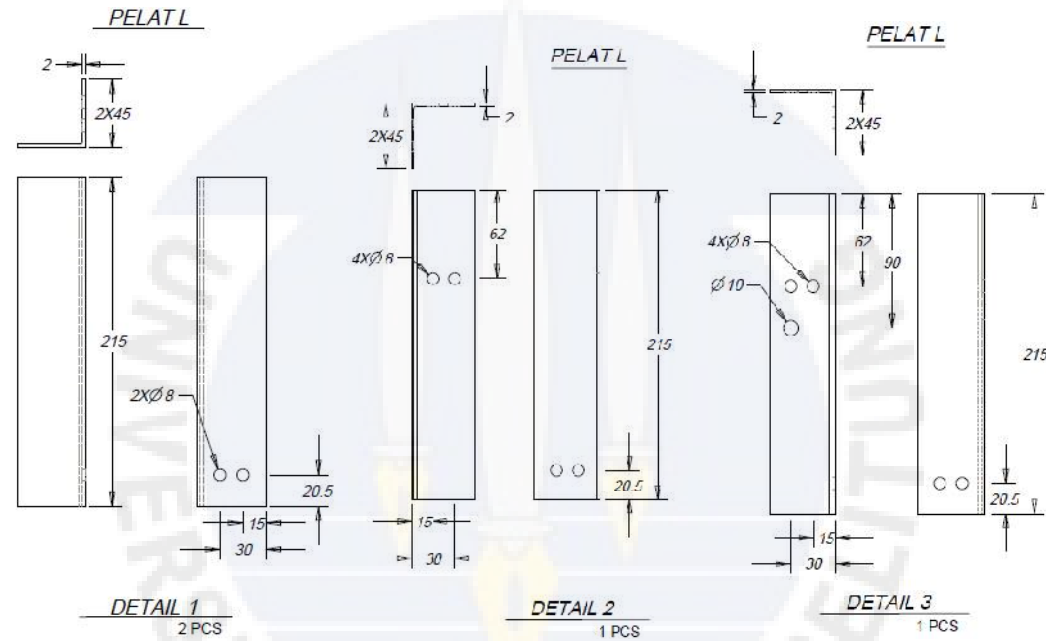

RANGKA DUDUKAN PRESS MESIN CETAK TERASI KAPASITAS
250 GRAM

Skala
1:5

Dilihat		
Digambar		Rhendy
Diperiksa		
Disetujui		



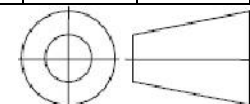

UNIVERSITAS BANGKA BELITUNG



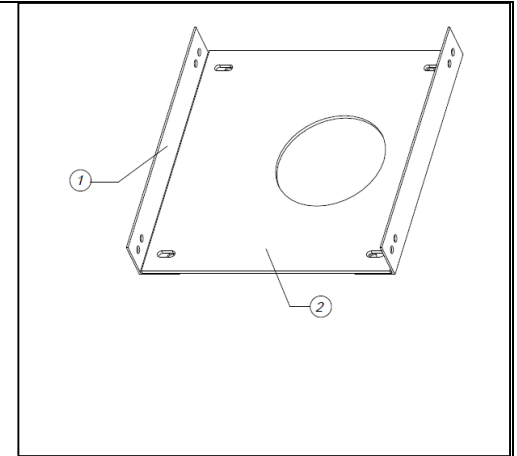
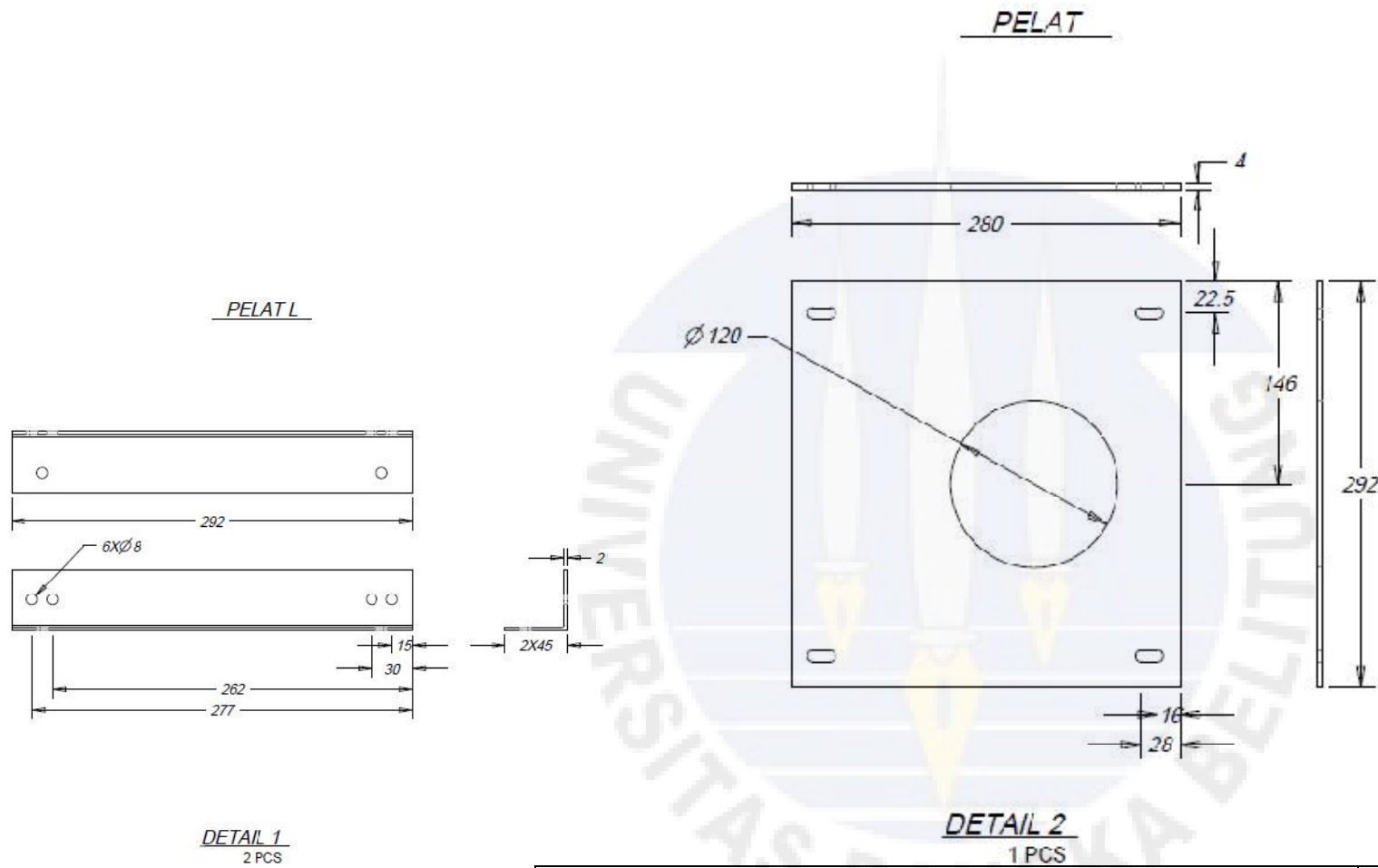

6

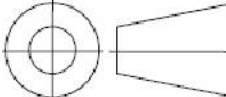

<p>RANGKA DUDUKAN MOTOR LISTRIK MESIN CETAK TERASI KAPASITAS 250 GRAM</p>	<p>Skala 1:5</p>	Dilihat	
		Digambar	Rhendy
		Diperiksa	
		Disetujui	
 <p>UNIVERSITAS BANGKA BELITUNG</p>			



3

ULIR (SCREW)

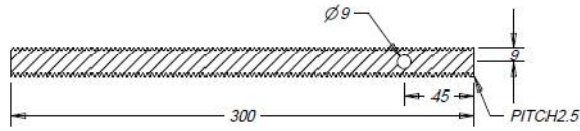

DETAIL 1
1 PCS

POROS LUBANG

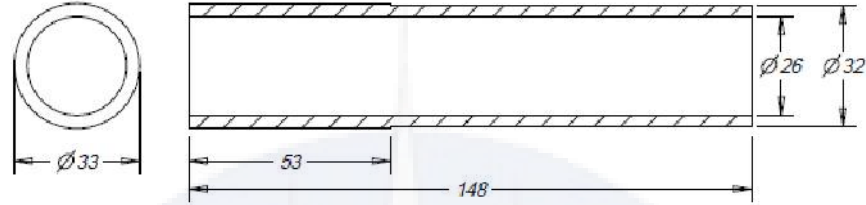

KET :
SKALA 1 : 2

DETAIL 2
1 PCS

MUR

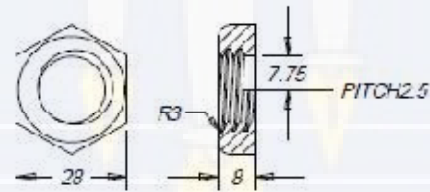

KET :
SKALA 1 : 2

DETAIL 3
2 PCS

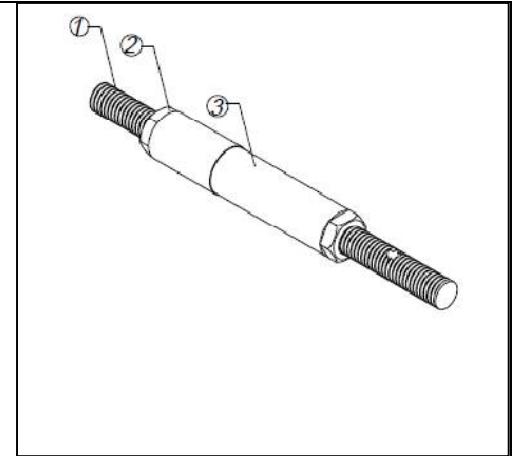

POROS TRANSMISI MESIN CETAK TERASI KAPASITAS 250
GRAM

Skala
1:5

Dilihat		
Digambar		Rhendy
Diperiksa		
Disetujui		



UNIVERSITAS BANGKA BELITUNG

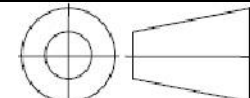



4

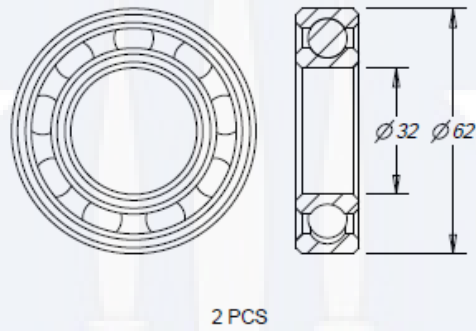
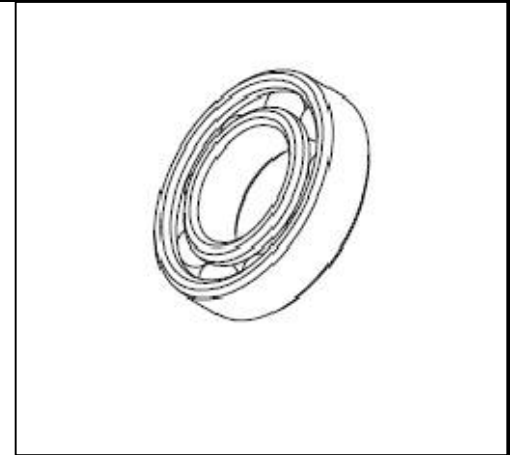

BANTALAN (BEARING) MESIN CETAK TERASI KAPASITAS 250 GRAM

Skala
1:2

Dilihat		
Digambar		Rhendy
Diperiksa		
Disetujui		



UNIVERSITAS BANGKA BELITUNG

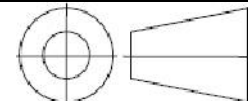



5

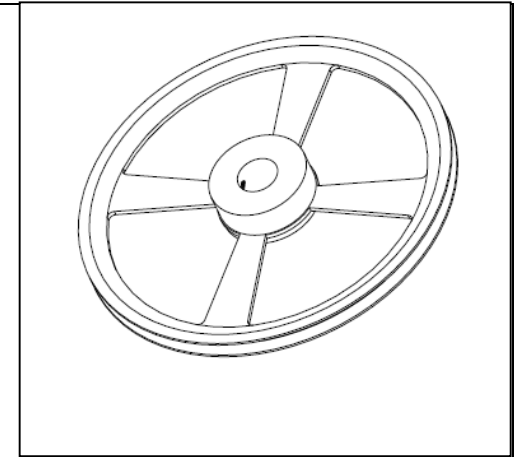
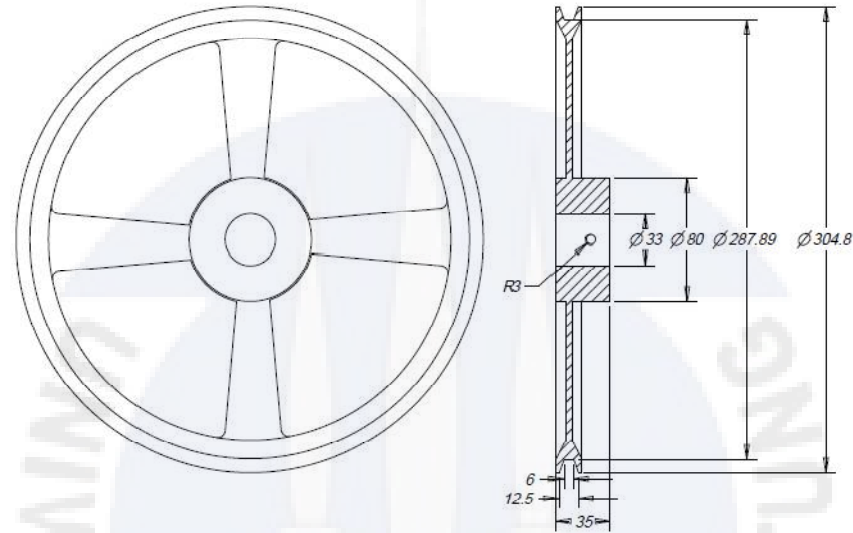

PULI BESAR MESIN CETAK TERASI KAPASITAS 250 GRAM

Skala
1:5

Dilihat		
Digambar		Rhendy
Diperiksa		
Disetujui		



UNIVERSITAS BANGKA BELITUNG

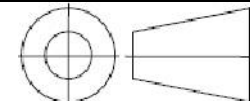



8

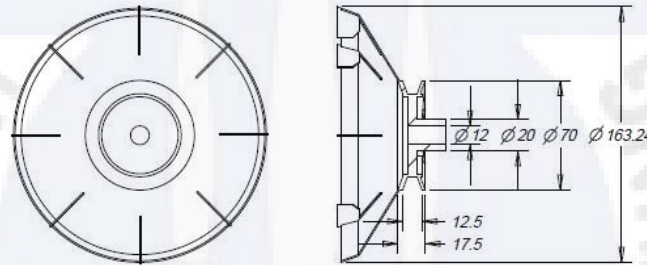
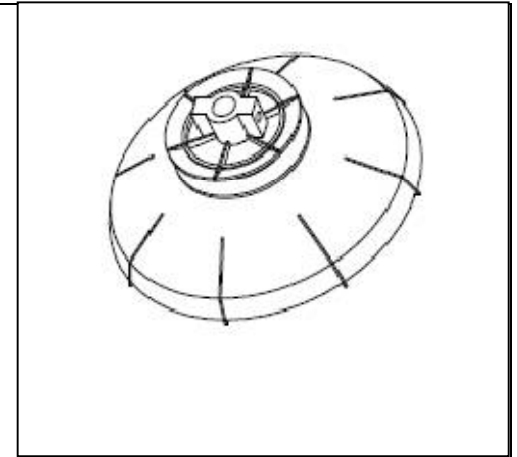

PULI KECIL MESIN CETAK TERASI KAPASITAS 250 GRAM

<i>Skala 1:5</i>	<i>Dilihat</i>		
	<i>Digambar</i>		<i>Rhendy</i>
	<i>Diperiksa</i>		
	<i>Disetujui</i>		



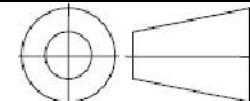

UNIVERSITAS BANGKA BELITUNG



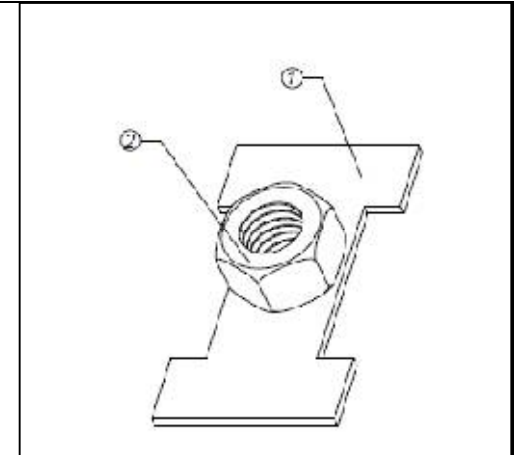
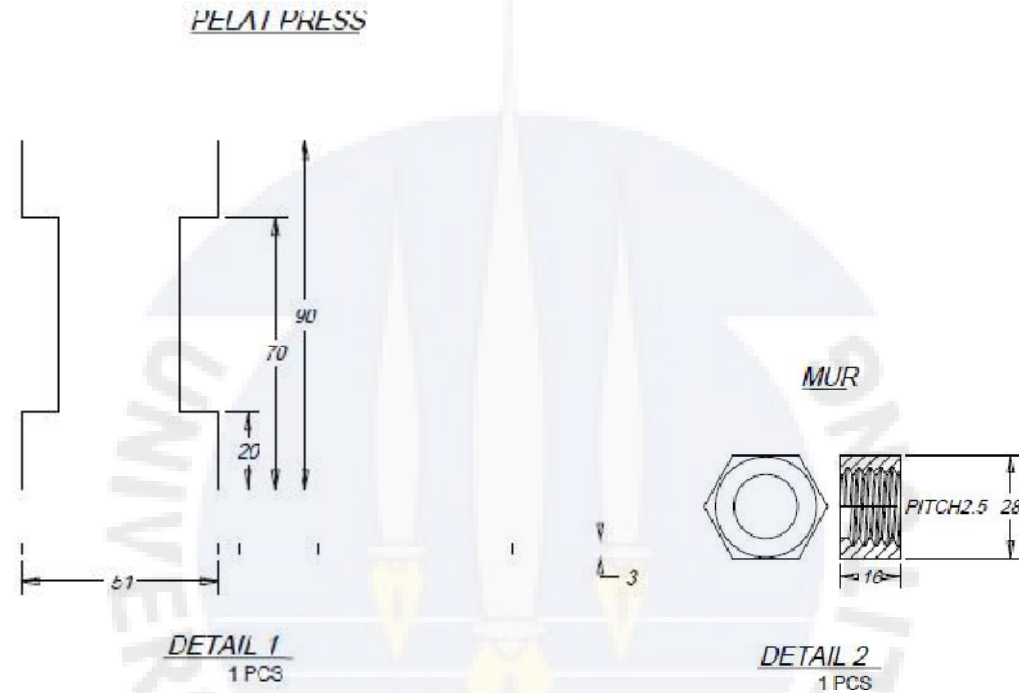

13

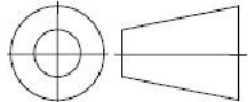

<p><i>PELAT PENEKAN MESIN CETAK TERASI KAPASITAS 250 GRAM</i></p>	<p><i>Skala</i> 1:2</p>	<i>Dilihat</i>		
		<i>Digambar</i>		<i>Rhendy</i>
		<i>Diperiksa</i>		
		<i>Disetujui</i>		
 <p>UNIVERSITAS BANGKA BELITUNG</p>				



17

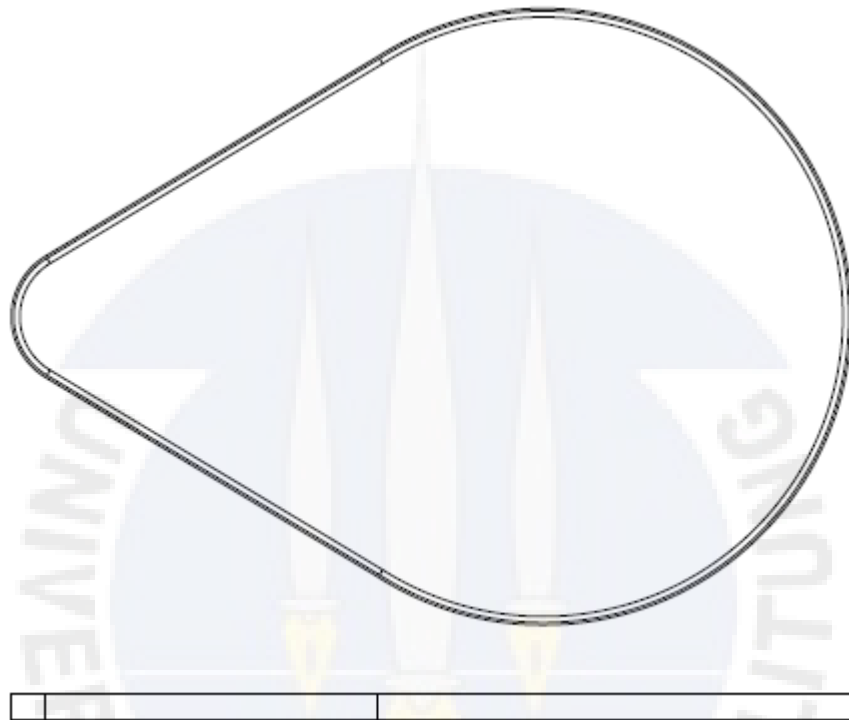

1 PCS

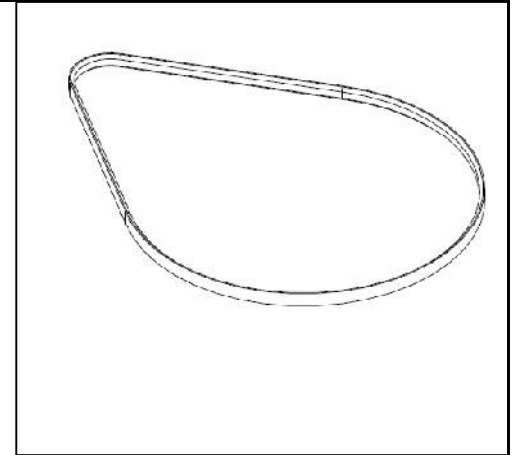

SABUK-V A43 TRANSMISI MESIN CETAK TERASI KAPASITAS 250 GRAM

Skala
1:5

Dilihat		
Digambar		Rhendy
Diperiksa		
Disetujui		



UNIVERSITAS BANGKA BELITUNG

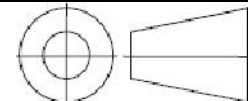



7

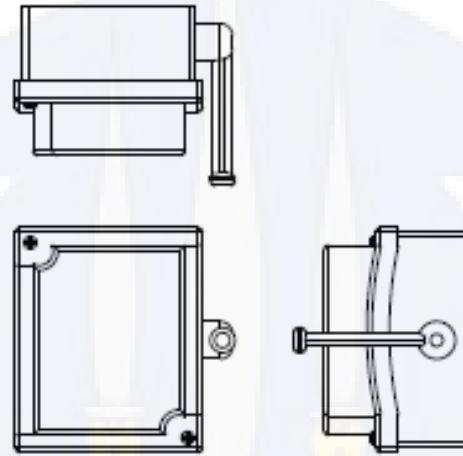

1 PCS

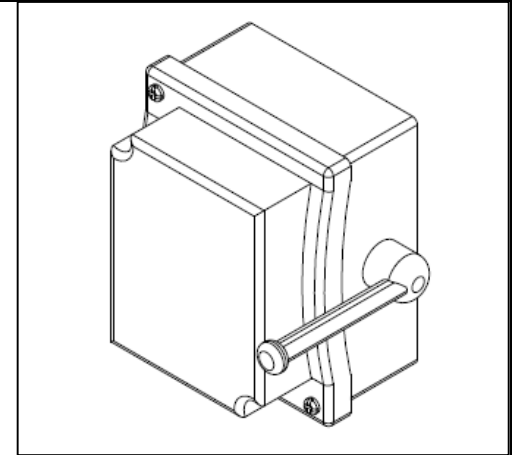

KONTAK HANDEL MESIN CETAK TERASI KAPASITAS 250 GRAM

Skala
1:2

Dilihat		
Digambar		Rhendy
Diperiksa		
Disetujui		



UNIVERSITAS BANGKA BELITUNG

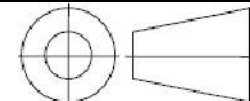



14

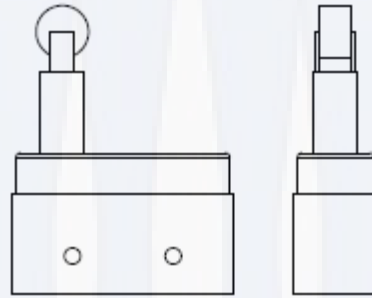

2 PCS

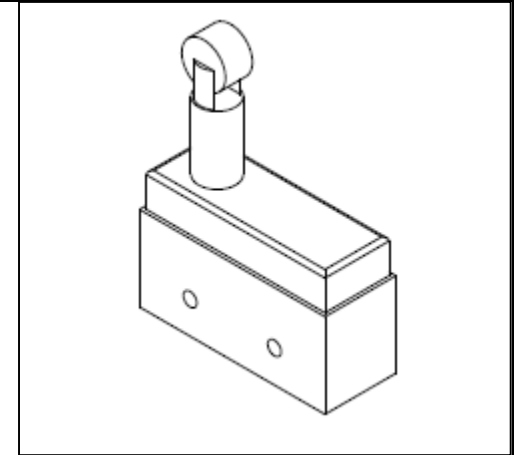

SWITCH ATAU STOPPER MESIN CETAK TERASI KAPASITAS 250 GRAM

Skala
1:2

Dilihat		
Digambar		Rhendy
Diperiksa		
Disetujui		



UNIVERSITAS BANGKA BELITUNG

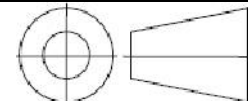



11

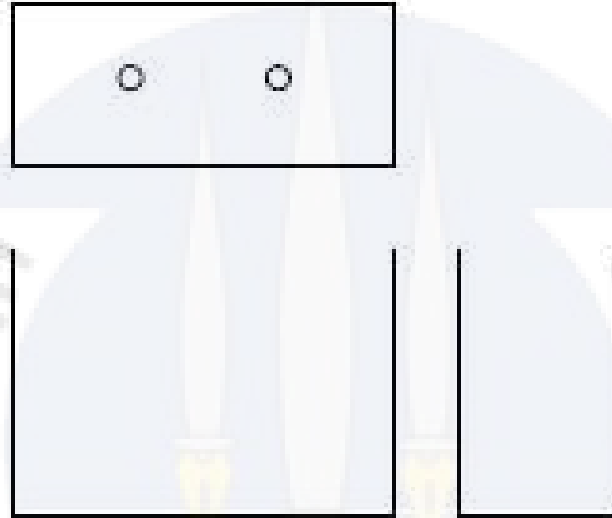

1 PCS

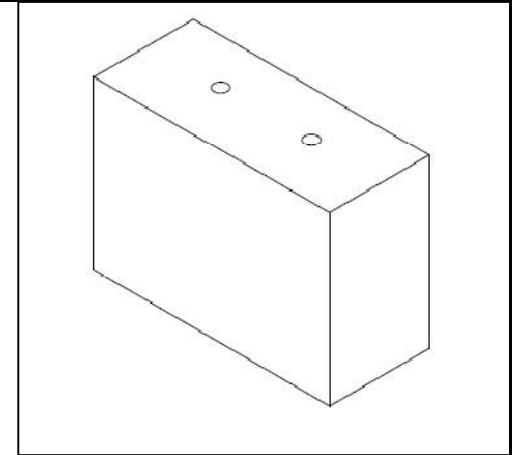

BOK KABEL MESIN CETAK TERASI KAPASITAS 250 GRAM

Skala
1:2

<i>Dilihat</i>		
<i>Digambar</i>		<i>Rhendy</i>
<i>Diperiksa</i>		
<i>Disetujui</i>		



UNIVERSITAS BANGKA BELITUNG

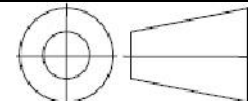



9

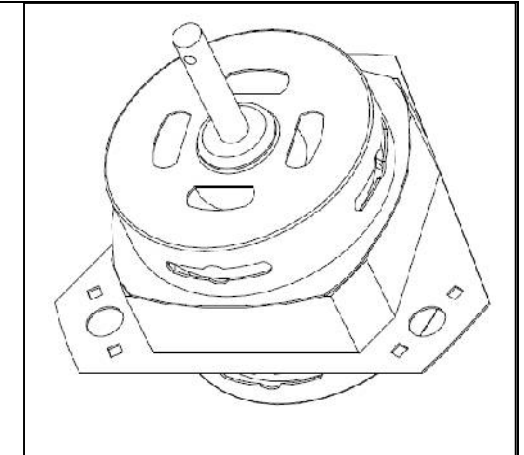
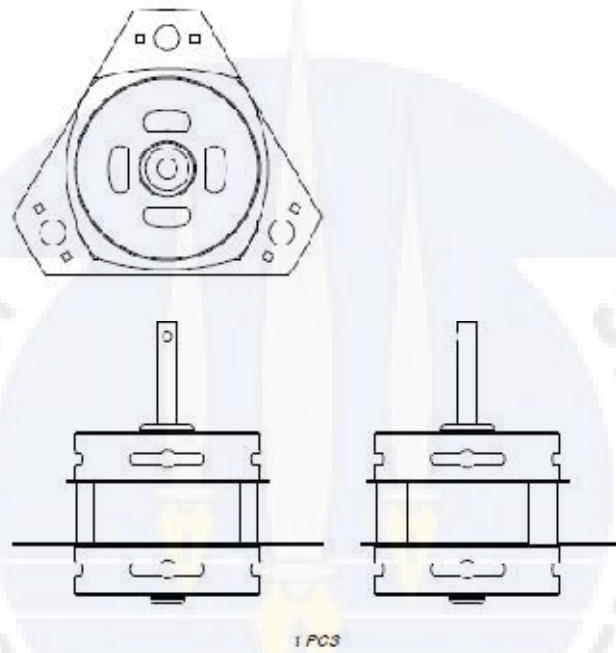

MOTOR LISTRIK MESIN CETAK TERASI KAPASITAS 250 GRAM

Skala
1:5

Dilihat		
Digambar		Rhendy
Diperiksa		
Disetujui		



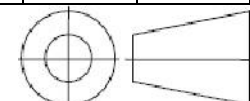

UNIVERSITAS BANGKA BELITUNG



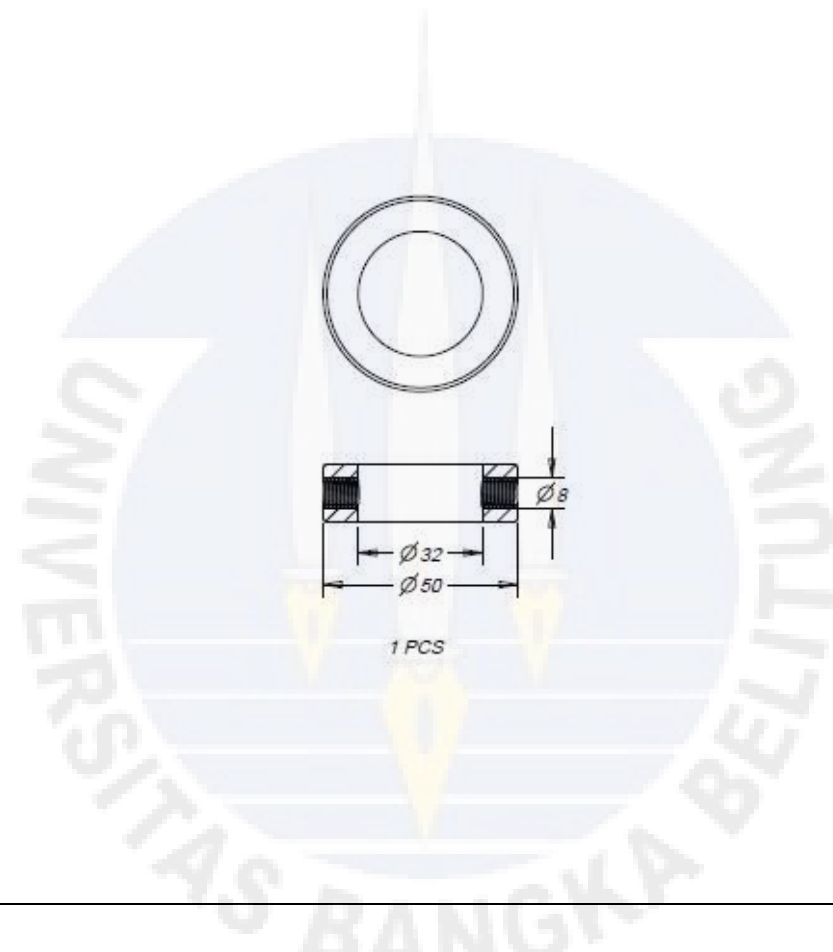
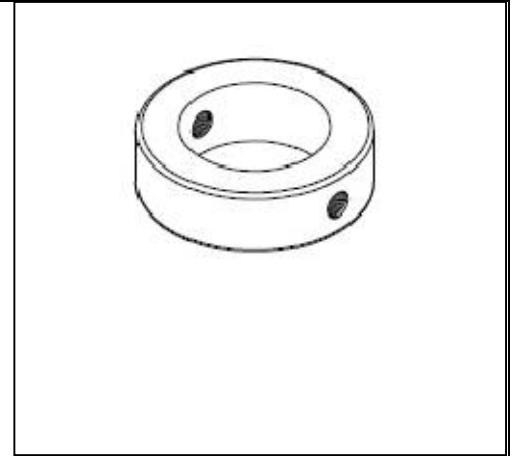

16

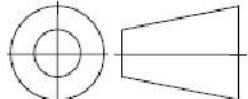

<p>PASAK PENAHAN POROS MESIN CETAK TERASI KAPASITAS 250 GRAM</p>	<p>Skala 1:2</p>	Dilihat		
		Digambar		Rhendy
		Diperiksa		
		Disetujui		
 <p>UNIVERSITAS BANGKA BELITUNG</p>				



15

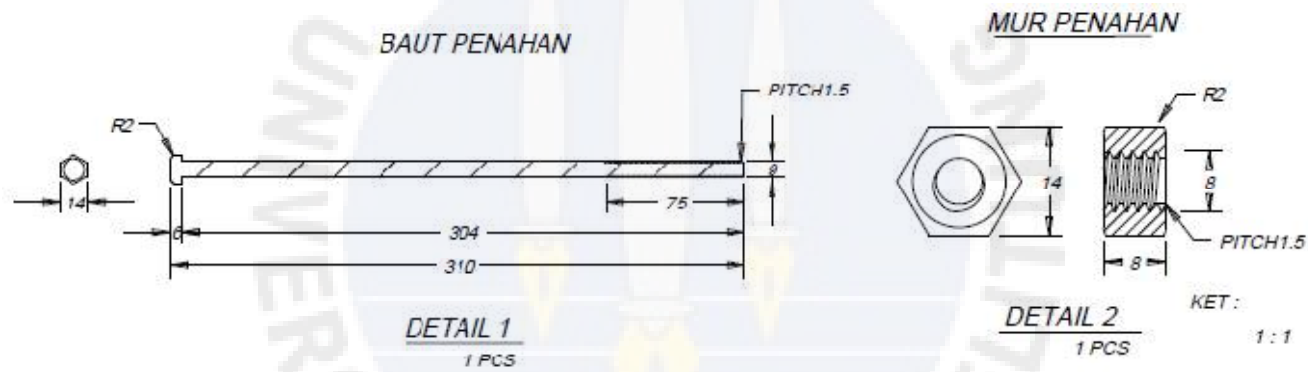
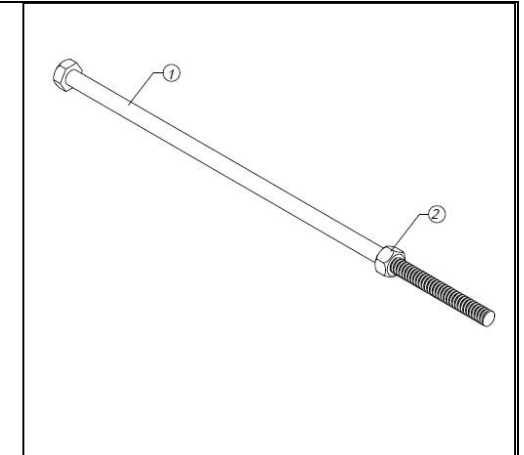

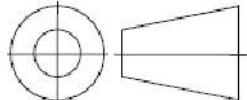
<p>BAUT PENAHAN MESIN CETAK TERASI KAPASITAS 250 GRAM</p>	<p>Skala 1:5</p>	<p>Dilihat</p>		
		<p>Digambar</p>		<p>Rhendy</p>
		<p>Diperiksa</p>		
		<p>Disetujui</p>		
 <p>UNIVERSITAS BANGKA BELITUNG</p>				



10

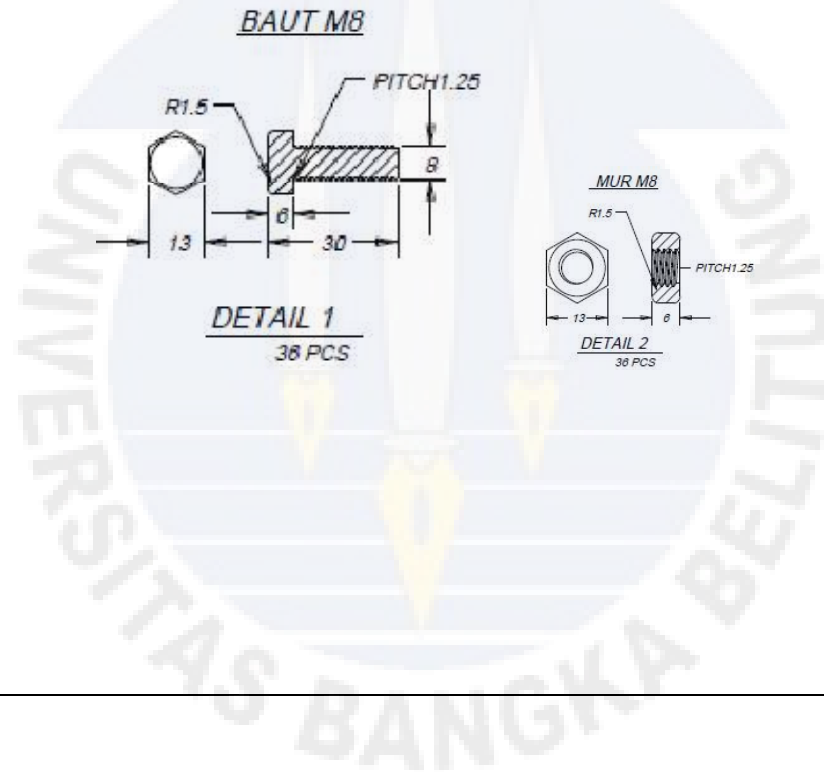
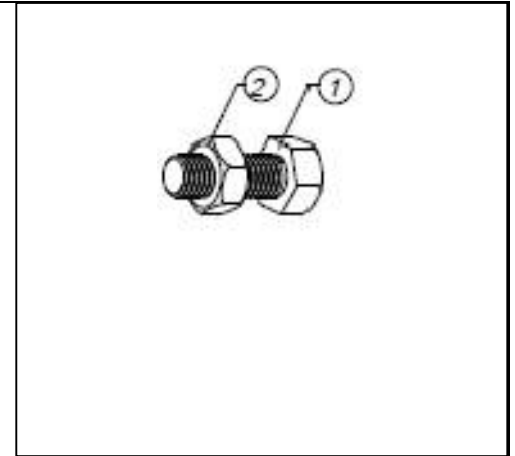

<p>SAMBUNGAN MESIN CETAK TERASI KAPASITAS 250 GRAM</p>	<p>Dilihat</p>		
	<p>Digambar</p>		<p>Rhendy</p>
	<p>Diperiksa</p>		
	<p>Disetujui</p>		

	<p>UNIVERSITAS BANGKA BELITUNG</p>	
---	------------------------------------	---



Lampiran 4. Foto Perakitaan Komponen Mesin Cetak Terasi Kapasitas 250 Gram

1. Memasang Komponen Mesin Cetak Terasi Kapasitas 250 Gram



2. Mesin Yang Sudah Selesai Dirakit



3. Percobaan Mesin Sebelum Bahan Adonan Dicetak



Lampiran 5. Foto Uji Kinerja Mesin Cetak Terasi Kapasitas 250 Gram

1. Memasukkan Bahan Adonan Kedalam Cetakan



2. Kontak Handel/Saklar Diturunkan Untuk Menghidupkan Mesin dan Melakukan Proses Penekanan



3. Kontak Handel/Saklar Dinaikkan Kembali dan Bahan Adonan Siap Dikeluarkan Kembali



Lampiran 5. Foto Uji Kinerja Mesin Cetak Terasi Kapasitas 250 Gram

4. Hasil Bahan Adonan Yang Disudah Diproses Dari Mesin Cetak Terasi Kapasitas 250 Gram

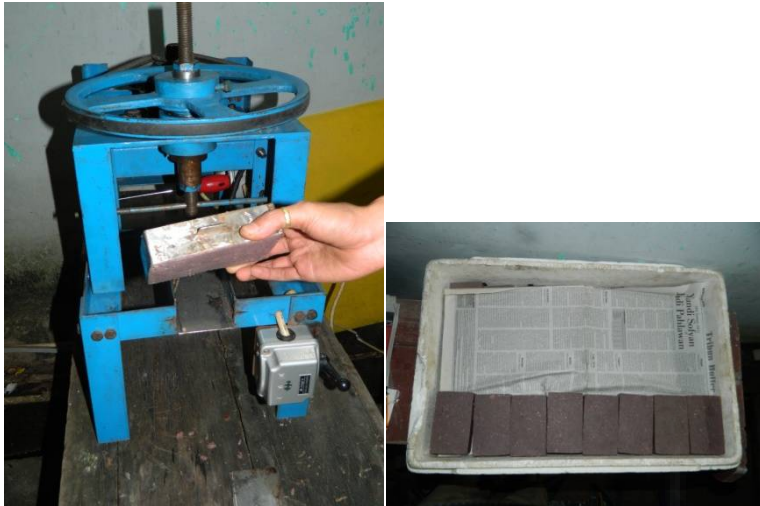

5.

